

4-terminal high precision current sensor specification

1.Scope

This specification applies to the following 4-terminals high precision current sensor for use in electronic equipments.

2.Part number

$\text{RL3264SW4} - \text{***M} - \text{F} - \text{T*}$
 ① ② ③ ④

Explanation of Resistance Value
 Eg.) $2 \text{ m}\Omega \rightarrow 002\text{M}$

- ① Type
- ② Nominal resistance
- ③ Resistance tolerance
- ④ Packaging form (T1 = 1,000pcs/reel ,T5 = 5,000pcs/reel)

3.Structure

Metallized Ni-alloy resistor and electrode on ceramic substrate, covered with heat resistive epoxy resin.

4.Dimensions

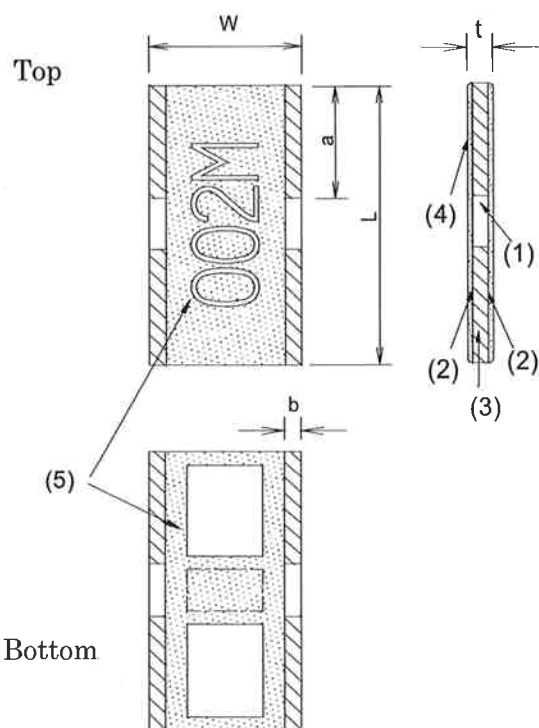

- (1) Substrate Alumina 96%
- (2) Resistor Ni-alloy
- (3) Terminals Sn-Pb or Sn(on Cu)
Sn is free from lead.
- (4) Protection film Heat resistive epoxy resin
- (5) Marking Epoxy resin

Symbol	Dimensions(mm)
L	6.4 ± 0.2
W	3.2 ± 0.2
t	0.5 ± 0.2
a	2.7 ± 0.2
b	0.4 ± 0.2

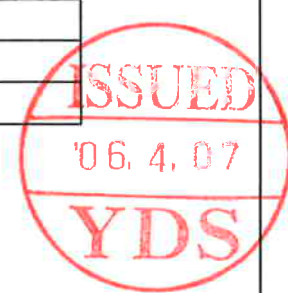

Marking

Top: Resistance value Eg.) $2 \text{ m}\Omega \rightarrow 002\text{M}$

Bottom: An alphabet that indicates manufacturing month, and quadrilaterals beside its both sides shall be marked.

Manufacturing month code reference is the annexed document 1 table 5 of JIS C 5201 - 1:1998

Autho	Check	Approval	Title	Description
K. Inomata	K. Nagano	A. Nakajima	RL3264SW4 4-terminals high precision current sensing	Specification
Apr.07.2006	Apr.07.2006	Apr.07.2006		Document # RL00-1126
				Rev. 0
				Yokohama Densi Seiko Co.,Ltd. Page 1/6

6.Schematic diagram

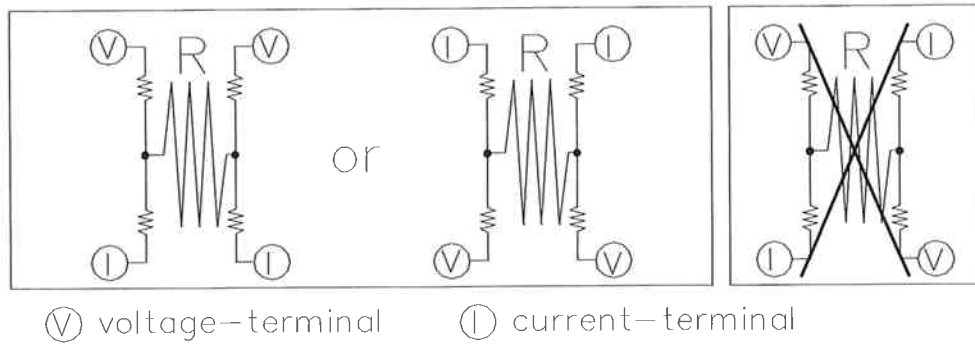

There is no difference between voltage-terminal and current terminal. But it is possibly causing to deteriorate its characteristics when you connect line across. You can't connect lines across each other

Resistance value of this product is called resistance value for current sensing and shows resistance value of sign R in the upper diagram. Resistance value between terminals shows resistance value added at terminal resistance.

7.Specification

Parameter	Specification
Resistance value for current sensing	1 mΩ ~ 10 mΩ 1mΩ step
Resistance tolerance	±0.5% (D) ±1.0% (F)
Terminal resistance	500 μΩ under
Temperature coefficient of resistance	1 mΩ ±300ppm/°C 2~4 mΩ ±200ppm/°C 5~10 mΩ ±100ppm/°C
Rated load	2 W (Derating curve···Figure-1)
Maximum over current	$I = \sqrt{(150/R)}$ [A] (10m sec. max.) Resistance value (Ω) Maximum current 200A Interval 60 sec min.
Operating temperature range	-40~+125°C
Rated ambient temperature	+70°C

Figure -1 Derating curve

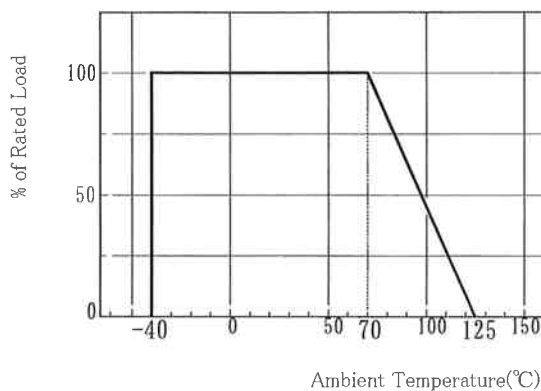

8. Reliability testing

Parameter	Conditions	Specification
Short time over load	Voltage of 1.5 times the rated voltage shall be applied for 5sec.	$\pm(0.5\% +0.0005\Omega)$
Load life	Rated voltage for 90min. followed by a pause of 30min. at a temperature of $70\pm 3^{\circ}\text{C}$. Cycles shall be repeated for 1000hrs.	$\pm(0.5\% +0.0005\Omega)$
Moisture load life	Rated voltage for 90min. followed by a pause of 30min. at a temperature of $60\pm 2^{\circ}\text{C}$ with relative humidity of 90%. Cycles shall be repeated for 1000h	$\pm(0.5\% +0.0005\Omega)$
Temperature cycle	$[-40^{\circ}\text{C} \ 30\text{min} \rightarrow \text{R.T.} \ 3\text{min} \rightarrow +125^{\circ}\text{C} \ 30\text{min} \rightarrow \text{R.T.} \ 3\text{min.}] \ 5\text{continuous cycles.}$	$\pm(0.5\% +0.0005\Omega)$
Soldering heating	Dipped into solder for $10\pm 1\text{sec.}$ at $260\pm 5^{\circ}\text{C}$	$\pm(0.5\% +0.0005\Omega)$
Substrate bending	Between fulcrums :90mm Bend width : 2mm Glass-epoxy board $t=1.6\text{mm}$	$\pm(0.5\% +0.0005\Omega)$
Solderability	Dipped into solder for $3\pm 0.5\text{sec.}$ at $235\pm 5^{\circ}\text{C}$ or $245\pm 5^{\circ}\text{C}$ (lead free)	A new solder shall cover min of 90 %

9. Packaging

Packing quantity , 1,000 or 5,000pieces/reel

Taping form	Figure-2
Peeling strength of seal tape	Figure-3
Reel form	Figure-4
Taping direction	Figure-5

Marking The following items shall be printed on the reel label.(Figure-6)

Part number
Quantity for each reel
Manufacturing month code
Manufacturer
Inspection number (Lot number)
The country of origin
Double dashed line.
No mark when finish of terminals is solder.

Figure-2 Plastic tape Taping form

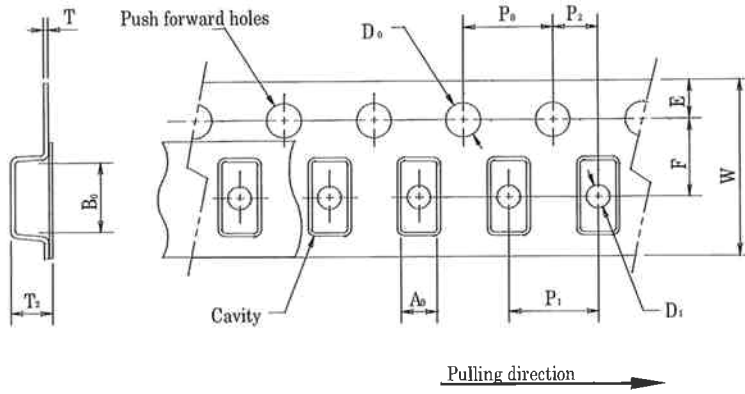

Symbol	Dimensions
A 0	3.43 ±0.2
B 0	6.63 ±0.2
W	12.0 ±0.3
F	5.5 ±0.05
E	1.75 ±0.1
P 0	4.0 ±0.1
P 1	4.0 ±0.1
P 2	2.0 ±0.05
D 0	1.5 +0.1/-0
D 1	1.5 +0.2/-0
T	0.3 max
T 2	1.5max

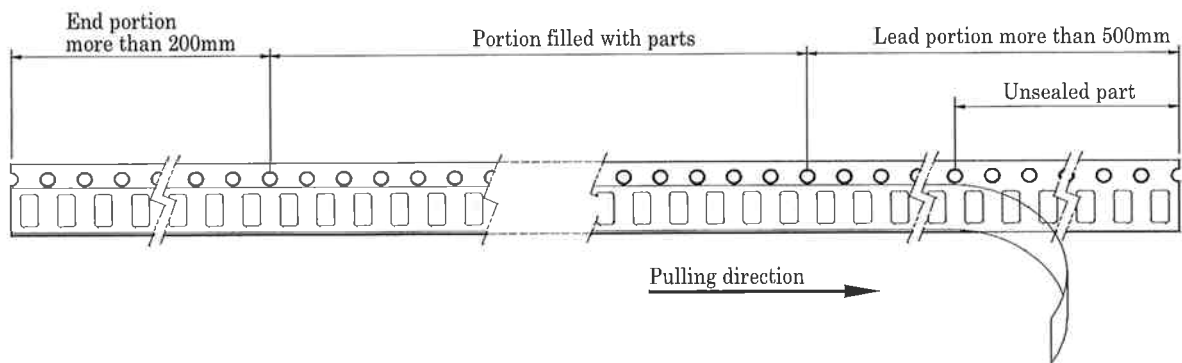

Figure-3 Peeling strength of seal tape

F = Peeling strength: 0.1 – 0.7N (10 - 71gf)

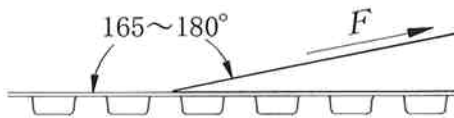
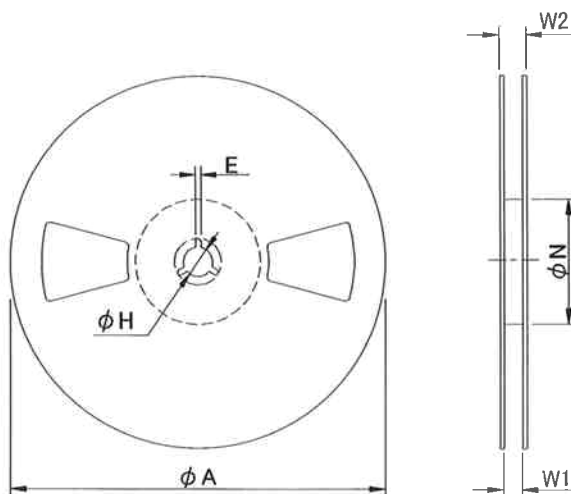

Figure-4 Reel form



Symbol	Dimensions(mm)	
	1000pcs/reel	5000pcs/reel
φ A	180+0/-3	255±1.0
φ H	13.0±0.2	13.0±0.3
E	2.0±0.5	2.0±0.2
φ N	60+1/-0	80±0.5
W1	13.0±0.3	13.5±1.0
W2	17.0±1.4	18.4 or less

(unit: mm)

Material: Plastic

Figure-5 Taping direction

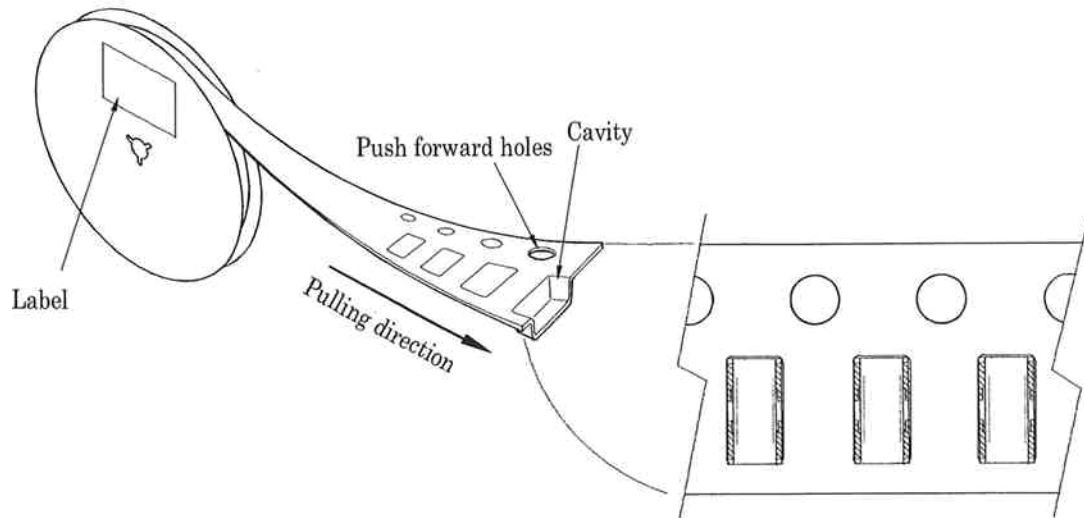
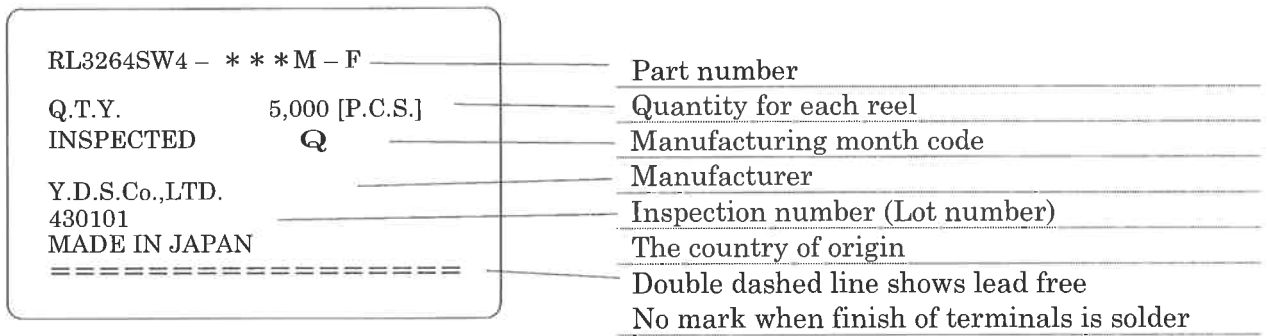

Figure-6 Reel label



[Revision history]

Rev.	Date of enactment	Author	Check	Approval	Revision content
0	Apr.7.2006	K.Inomata	K.Nagano	A.Nakajima	First edition

Title RL3264SW4 4-terminal high precision current sensor	Description Specification	Document # RL00-1126	Rev. 0
		Yokohama Densi Seiko Co.,Ltd.	Page 6/6